

ENGINE POWERED ARTICULATING BOOM LIFTS

AB15J PLUS (AB480J PLUS)

Compliant with AS 1418 · 10 standards

HIGHLIGHTS

Excellent Rough Terrain Performance

- The machine features great rough terrain performance thanks to its active oscillating function, combined with 4 wheel drive, 40% gradeability and high ground clearance making it easily adaptive to both indoor and outdoor applications

Large Platform Capacity

- Two persons with tools can be easily loaded in the platform to complete jobs efficiently by its leading platform capacity up to 300 kg

Efficient Hydraulic System

- Function pump updated from gear pump to piston pump, could providing more oil flow and higher oil pressure, make the multi boom function better, improve the operation efficiency

Greater Tilt Rating

- The machine can be easily adaptive to terrains where requires greater tilt rating and help to boost work efficiency

Ultimate HMI Experience

- Easy trouble shooting, manuals free. One button for fault inquiry, and all faults will be displayed on the screen without codes, easily readable to minimize downtime
- Easy calibration, tools free. Additional tools are not needed for calibration



Standard Features

4WD×2WS	Fault diagnosis system	Telematic ready
Hydraulic platform leveling	Display screen	Battery isolator
Flashing beacon	Emergency lowering system	Secondary guarding system
Proportional control	Weight management system	White noise alarm
Tilt protection system	Non-marking tires	Half-mesh for platform
Manual storage box		

Options & Accessories

Wheel nut indicators	AC power to platform	Telematic device
Fire extinguisher/Bracket	Mine spec	Driving light

SINOBOOM™

PARTNERS IN ACCESS™

🌐 SINOBOOM.AU | 📞 03 8905 1550

HO: BRISBANE – 39 ALTA ROAD, CABOOLTURE QLD 4510 | SYDNEY – 1/3 VOYAGER CT, GLENDENNING NSW 2761

MELBOURNE – 32-34 MARNI, DANDENONG SOUTH VIC 3175

ENGINE POWERED ARTICULATING BOOM LIFTS

AB15J PLUS (AB480J PLUS)

Compliant with AS 1418 · 10 standards

Model	AB15J Plus (AB480J Plus)
Dimensions	
Max Platform Height	14.7 m (48'3")
Max Working Height	16.7 m (54'9")
Max Horizontal Reach	8.5 m (27'11")
Max Horizontal Working Envelope	9.1 m (29'10")
Max Up and Over Clearance	7.3 m (23'9")
A Stowed Length	7.49 m (24'7")
B Stowed Width	2.3 m (7'7")
C Stowed Height	2.28 m (7'6")
Stowed Length (Transport)	5.75 m (18'10")
Stowed Width (Transport)	2.3 m (7'7")
Stowed Height (Transport)	2.66 m (8'9")
D Wheelbase	2.3 m (7'7")
Ground Clearance	0.35 m (1'2")
Platform Size (L×W×H)	1.83 m × 0.85 m × 1.1 m (6' × 2'9" × 3'7")
Performance	
Max Platform Capacity	300 kg (661 lbs)
Max Platform Occupants	2 Persons
Drive Speed (Stowed)	4.5 km/h (2.8 mph)
Drive Speed (Raised)	1.0 km/h (0.6 mph)
Gradeability	40%
Turntable Rotation	360° /Continuous
Platform Rotation	180°
Tilt Rating	5°
Turning Radius(Inside/Outside)	1.82 m/4.78 m (6' / 15'8")
Turntable Tail-Swing	0.1 m(4")
Max Allowable Side Force	400 N (90 lbf)
Max Allowable Wind Speed	12.5 m/s (28 mph)
Tire Spec/Type	33×12D610 /foam-filled 33×12-20 /solid
Power	
Drive × Steer	4 WD × 2 WS
Engine	43.2 kW/2400 rpm/ V2403-CR-TIE4B-SBM-2/Kubota// EPA Tier 4 36 kW/2600 rpm/ V2403BM-DI-CT04/Kubota// China IV
Hydraulic Tank Capacity	112 L (24.6 gal (UK)/29.6 gal (US))
Diesel Tank Capacity	55 L (12.1 gal (UK)/14.5 gal (US))
System Voltage	12 V DC
Weight	
Weight	8,070kg (17,791 lbs) (Engine power ≥ 36kw)
Standards Compliance	AS 1418 · 10

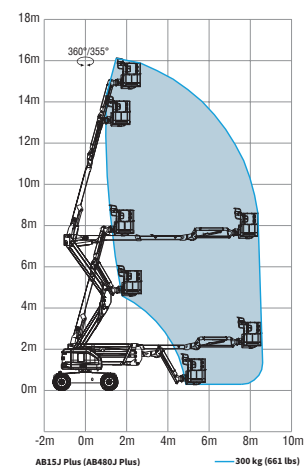
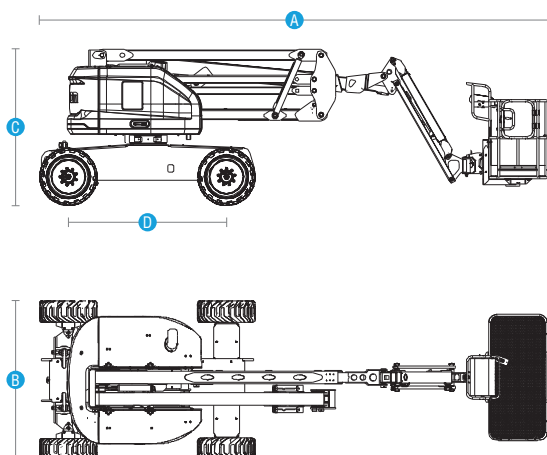

This document is provided for information purposes only and reflects product information available at the time of publication. Sinoboom Intelligent Equipment Pty Ltd reserves the right to change specifications, designs, and equipment without notice and makes no representations or warranties. Where indicated, AS-marked platforms conform to AS/NZS 1418.10:2011. Refer to the applicable Sinoboom Operating, Maintenance, and Parts Manuals for correct use and procedures. 03.2026